



ASPIRE

35mm STRUCTURAL GUIDE 
THE PERFECT PARTNER FOR THE TRADE



The following guide has been devised so as to allow the correct selection of components for a range of standard conservatory styles.

The information has been developed from an extensive programme of structural analysis and has been simplified as far as possible. It should be noted however, that a certain amount of information will be required to allow accurate selection of the components.

The information required to use the guide is as follows:

Conservatory size and style
Glazing type
Location
Exposure (town or country)
Approx. altitude of site
Approx. distance from sea

Generally, the dominant load on a roof is the snow load and therefore reference to loads are only made to **sections 4-6**. Some areas of the United Kingdom however with high altitude/ exposed/coastal locations may have wind loads that are higher than the snow loads associated with that area. For installations in these type of areas where the wind loading is dominant, reference should be made to **section 3** or contact made with the K2 Technical Department.

Structural stability is dependent not only on individual components but also on the interaction of the structure as a whole. Careful consideration must be given to the supporting structure beneath the roof such as the vertical side frames of PVC or timber and associated brickwork below which should be designed in accordance with the relevant British Standards for both vertical and lateral loadings.

If you are in any doubt about the loading of the vertical side frames it is advised you contact the technical department of your side frame supplier for guidance.

With reference to this structural guide it is assumed that the conservatory is being attached to an existing building and is not freestanding.



Listed below is a step-by-step procedure for the use of this guide. If you are in any doubt on any aspect of the guide then please contact the K2 Technical Department for advice.

STEP 1 Style and size of conservatory

Check these guidelines for the style of conservatory required and all relevant sizes. Make sure that the roof is not over the maximum sizes given in section 1 of this Structural Guide.

STEP 2 Determine the snow load

Determine the snow load from the British Isles map in **section 2**.

STEP 3 Location of site

If the conservatory is to be installed in an exposed country location, exposed coastal location or at high altitude, then please refer to **section 3** to ascertain whether the wind load is the dominant factor. If so or you are in any doubt, contact K2 Technical Department for advice.

STEP 4 Select transom glazing bar

Select the correct transom glazing bar for the required glazing type, bar spacing and loading conditions from **section 4**. There are two sections shown here depending on the style of roofing:

- a. Victorian/Georgian Style
- b. Lean to Style
- c. 35mm Low Pitch System

STEP 5 Select hip glazing bar

Select the correct hip bar for the required glazing type, bar spacing and loading conditions from **section 5**. There are two sections shown here depending on the style of roof:

- a. Victorian Hip Bar
- b. Georgian Hip Bar

STEP 6 Tie Bar Guide

Determine the tie bar requirement for the proposed roof using **section 6**.

STYLE AND SIZE OF CONSERVATORY

STRUCTURAL GUIDE

All sizes given are based on internal frame dimensions.

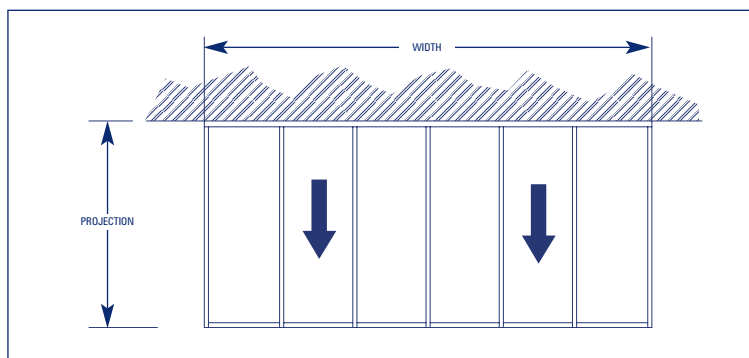

LEAN TO

	MAXIMUM WIDTH	MAXIMUM PROJECTION
Glass	no limit	see section 4b
Polycarbonate	no limit	see section 4b

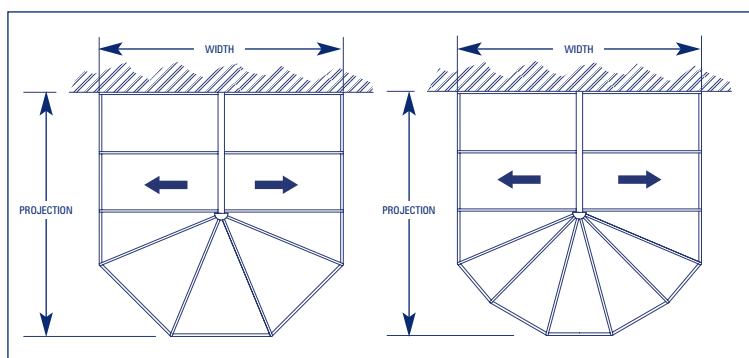

VICTORIAN

	MAXIMUM WIDTH	MAXIMUM PROJECTION
Glass	5750mm	6500mm
Polycarbonate	6500mm	6500mm

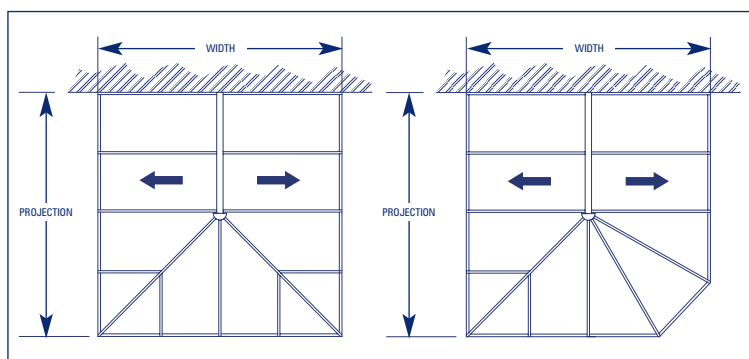

GEORGIAN

	MAXIMUM WIDTH	MAXIMUM PROJECTION
Glass	5250mm	6500mm
Polycarbonate	6000mm	6500mm

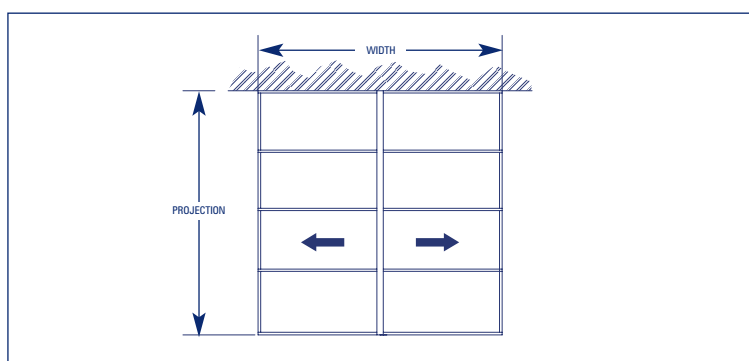

GABLE

	MAXIMUM WIDTH	MAXIMUM PROJECTION
Glass	5750mm	6500mm
Polycarbonate	6500mm	6500mm

If the roof size is outside these sizes please contact the K2 Technical Department for advice. Telephone 01204 554 554.

- Design snow load of 0.8kN/m² (80kg/m²) or more
- Design snow load of 0.6kN/m² (60kg/m²) or more
- Wind Speed m/s

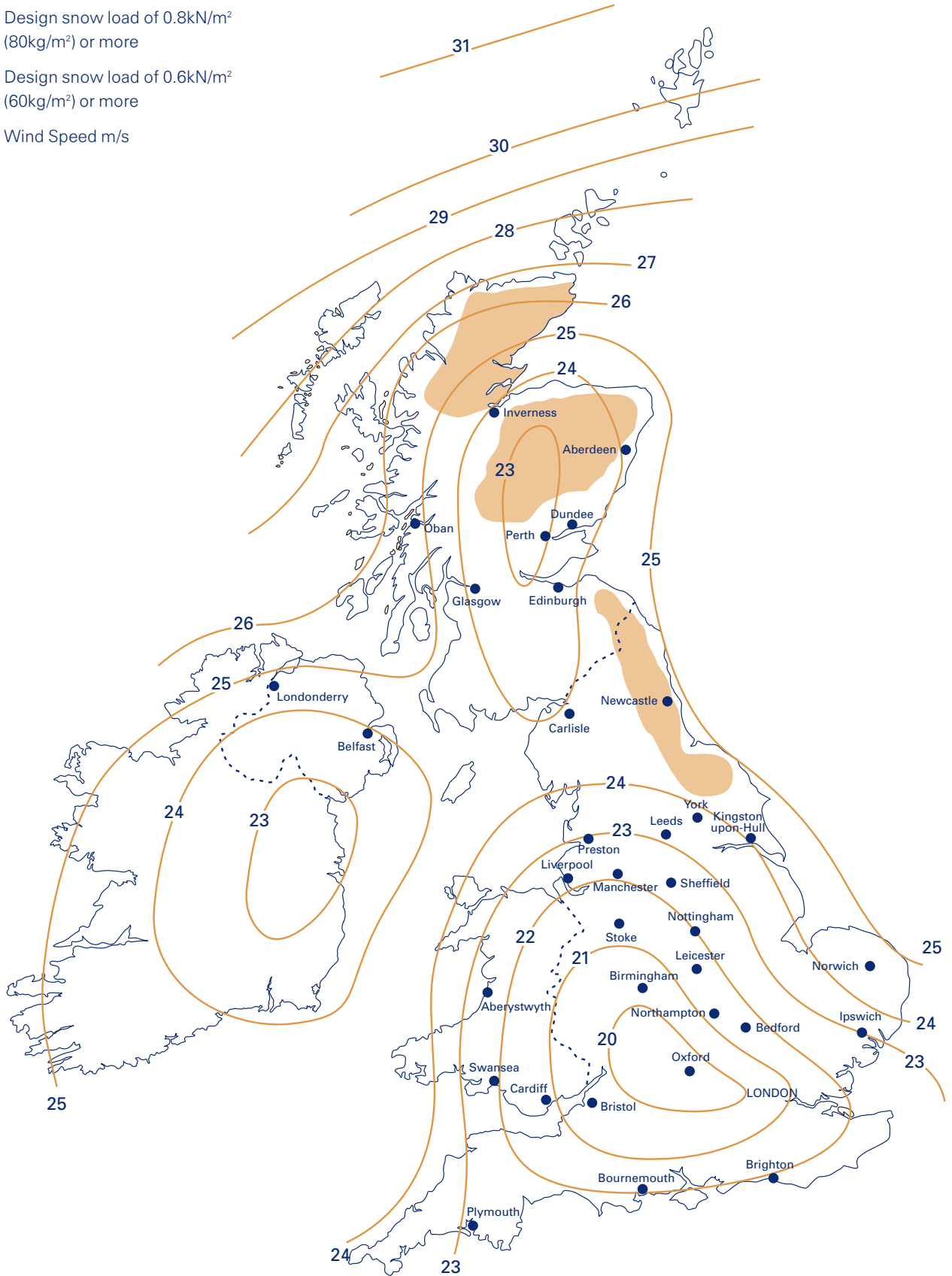

SNOW LOADING

STRUCTURAL GUIDE

Snow Altitude Factor

For conservatory installations less than 100m above sea level the 0.6kN/m² and 0.8kN/m² snow regions indicated on the map (page 5) can be utilised.

For installations at altitudes greater than 100m and less than 223m above sea level within the 0.6kN/m² of the map the 0.8kN/m² table can be used.

For installations at altitudes greater than 223m within the 0.6kN/m² and greater than 100m in the 0.8kN/m² region, guidance should be sought from the K2 Technical Department.

If in doubt about the altitude of a particular installation refer to local Ordnance Survey map.

References

Reference has been made to the following publications in the production of this document:

BS 6399 Part 2	Loading for Buildings - Wind Loads
BS 6399 Part 3	Loading for buildings - Snow Loads
BS 8118	Structural Use of Aluminium
BS 5516	Design and Installation of Sloping and Vertical Patent Glazing
BS 6262	Glazing for Buildings

Acknowledgment

Extracts from BS 6399 Part 2: 1997 are reproduced with the permission of BSI under license number 2000SK/0609.

Complete standards can be obtained from BSI Customer Services, 389 Chiswick High Road, London W4 4AL.

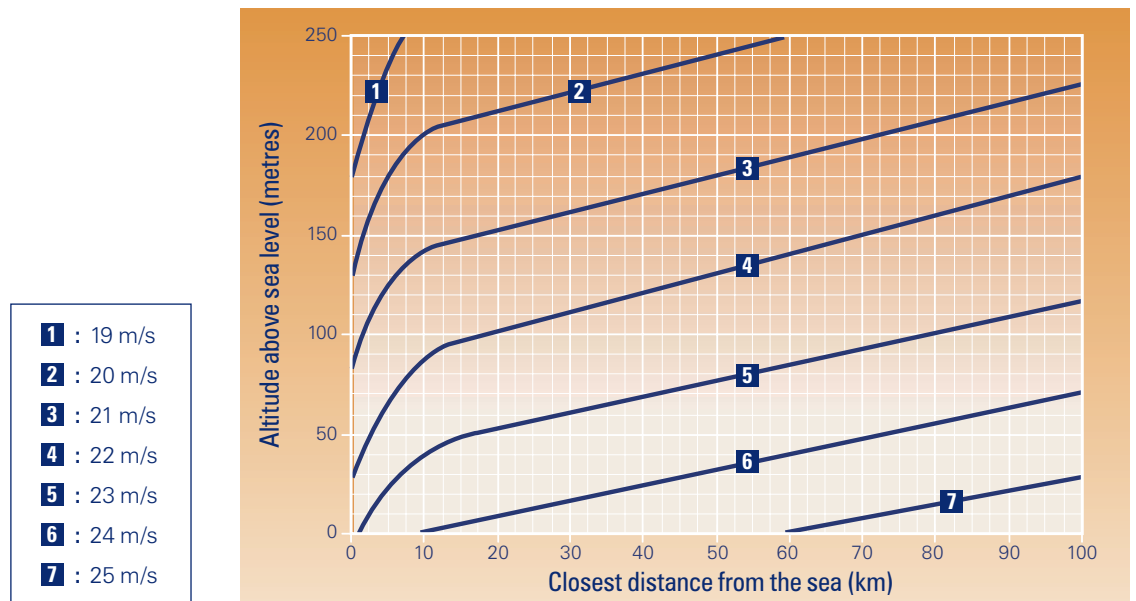
Dominant Wind Load Basic Speeds0.6kN/m² Snow Load on a Polycarbonate Roof in the Country**Dominant Wind Speed Table**

Multiplication Factors

0.8kN/m ² snow load roofs	1.16
Location in city/town (town extending >2m upwind from site)	1.11
4-16-4mm double glazed units	1.03
6-16-6mm double glazed units	1.06

Please contact the K2 Technical Department if the site is subject to the following categories:

- Where dominant forces wind speeds are greater than those from the illustrated map (page 5) for the area in question.
- Locations near the summit of a hill, crest of a cliff, escarpments or ridges.
- For conservatories of overall height greater than 3.5m.

VICTORIAN/GEORGIAN TRANSOM SPAN CHART

STRUCTURAL GUIDE

POLYCARBONATE

Example Calculation

Half width multiplied by slope factor table below equals effective span.

Example: 5000mm overall width gives 2500mm half width. 2500mm multiplied by 1.104 (30 degrees) equals 2760mm effective span.

Slope Calculation Factor

Slope Angle (degrees)	20	25	30	35
Span Multiplication Factor	1.044	1.070	1.104	1.148

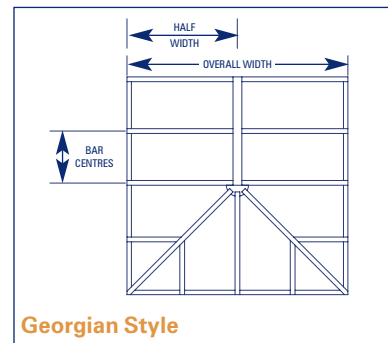
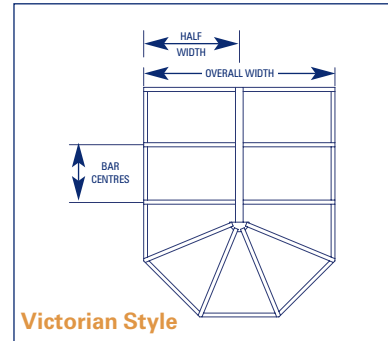

- 1** : 25mm Heavy Duty Bar/35mm Aspire
- 2** : 16mm Heavy Duty Bar
- 3** : 25mm Standard Bar
- 4** : 16mm Standard Bar

Please note that overall sizes of the required roof design must not exceed those stated in section 1.

- 1** : 25mm Heavy Duty Bar/35mm Aspire
- 2** : 16mm Heavy Duty Bar
- 3** : 25mm Standard Bar
- 4** : 16mm Standard Bar

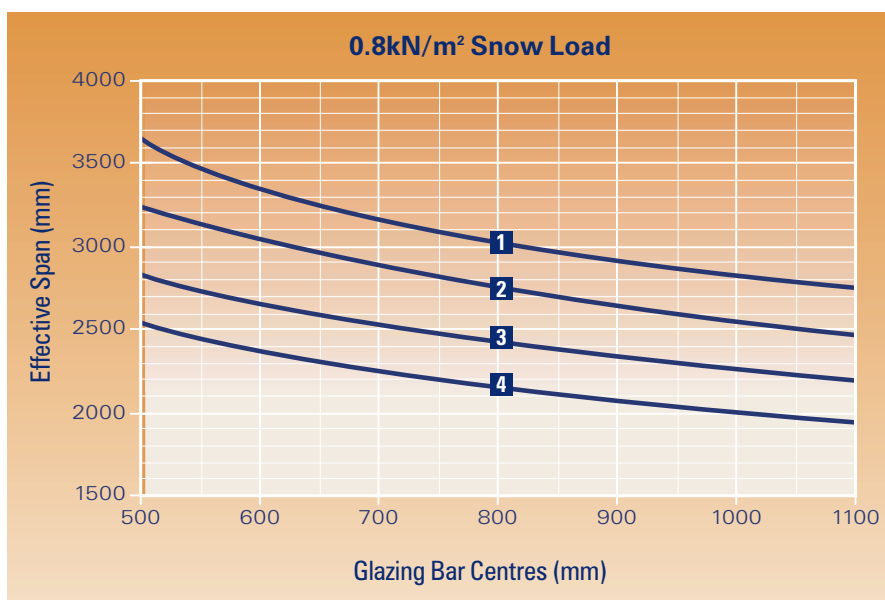
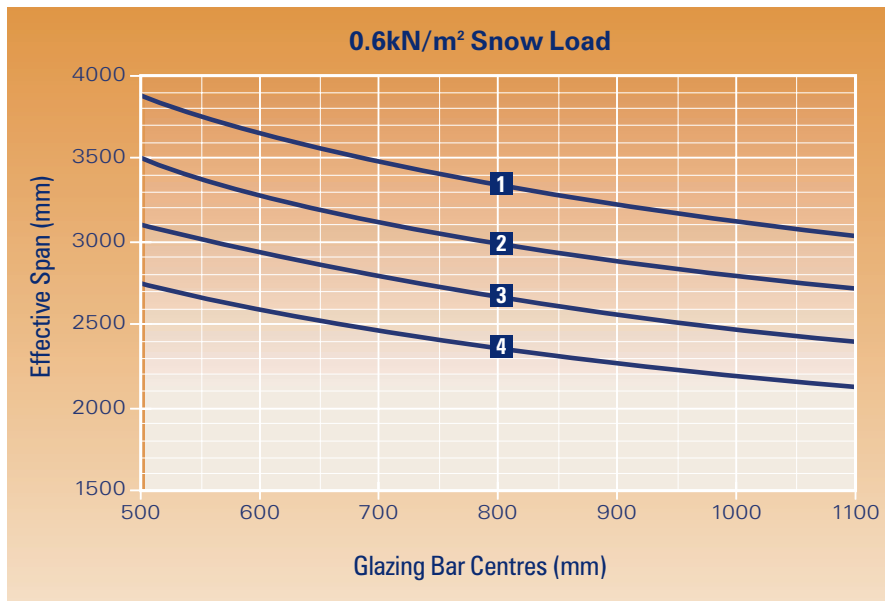

VICTORIAN/GEORGIAN TRANSOM SPAN CHART

STRUCTURAL GUIDE

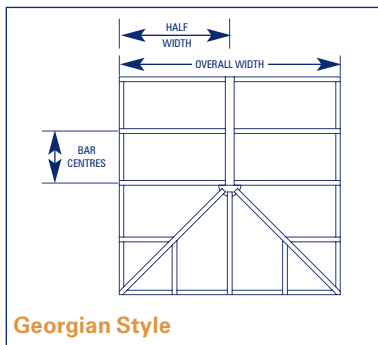
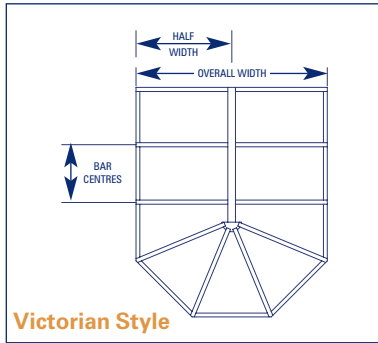

- 1** : 25mm Heavy Duty Bar
- 2** : 25mm Standard Bar

Please note that overall sizes of the roof design must not exceed those stated in section 1.

- 1** : 25mm Heavy Duty Bar
- 2** : 25mm Standard Bar

DOUBLE GLAZED UNITS (4:16:4mm)

Example Calculation

Half width multiplied by slope factor table below equals effective span.

Example: 5000mm overall width gives 2500mm half width. 2500mm multiplied by 1.104 (30 degrees) equals 2760mm effective span.

Slope Calculation Factor				
Slope Angle (degrees)	20	25	30	35
Span Multiplication Factor	1.044	1.070	1.104	1.148

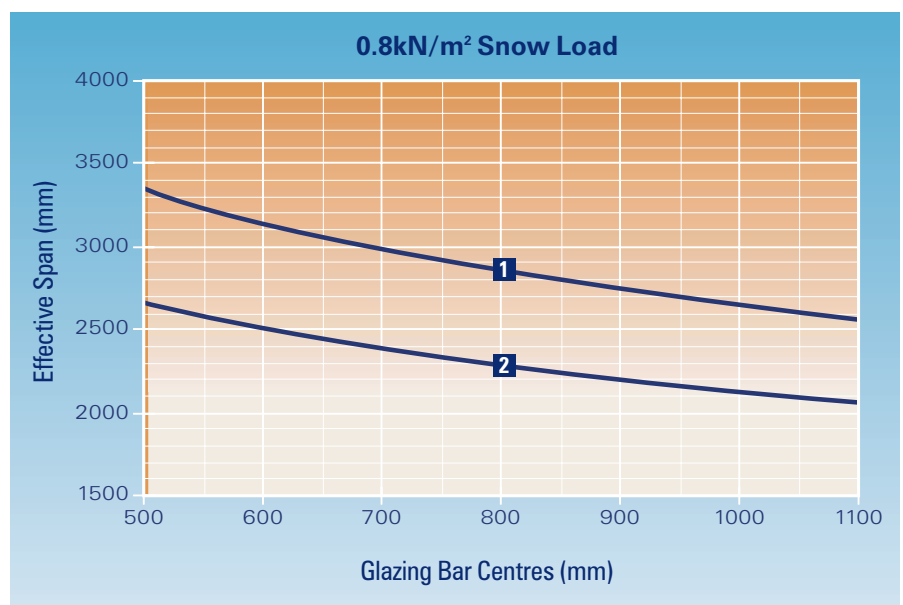
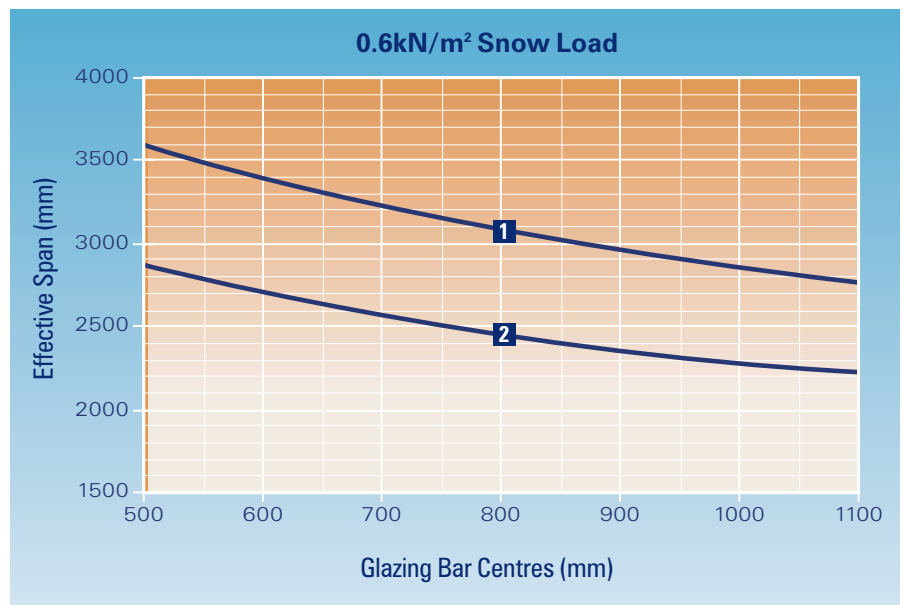

VICTORIAN/GEORGIAN TRANSOM SPAN CHART

STRUCTURAL GUIDE

DOUBLE GLAZED UNITS (4:14:6.4mm)

Example Calculation

Half width multiplied by slope factor table below equals effective span.

Example: 5000mm overall width gives 2500mm half width. 2500mm multiplied by 1.104 (30 degrees) equals 2760mm effective span.

Slope Calculation Factor

Slope Angle (degrees)	20	25	30	35
Span Multiplication Factor	1.044	1.070	1.104	1.148

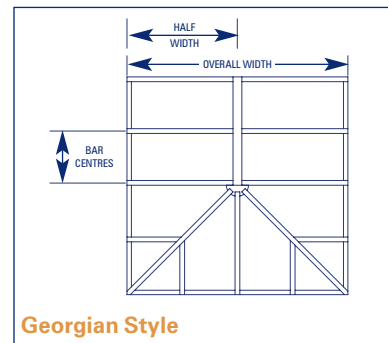
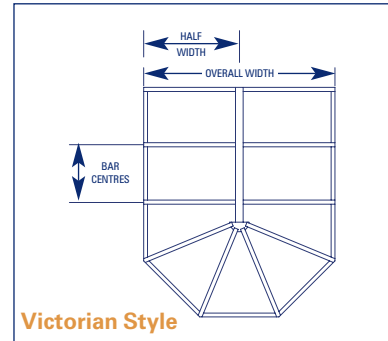

- 1** : 25mm Heavy Duty Bar
- 2** : 25mm Standard Bar

Please note that overall sizes of the required roof design must not exceed those stated in section 1.

- 1** : 25mm Heavy Duty Bar
- 2** : 25mm Standard Bar

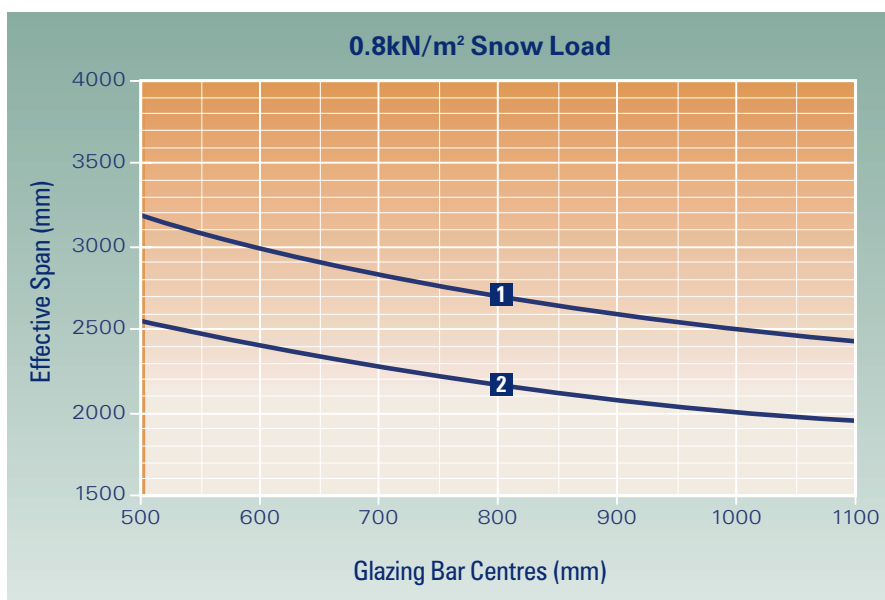
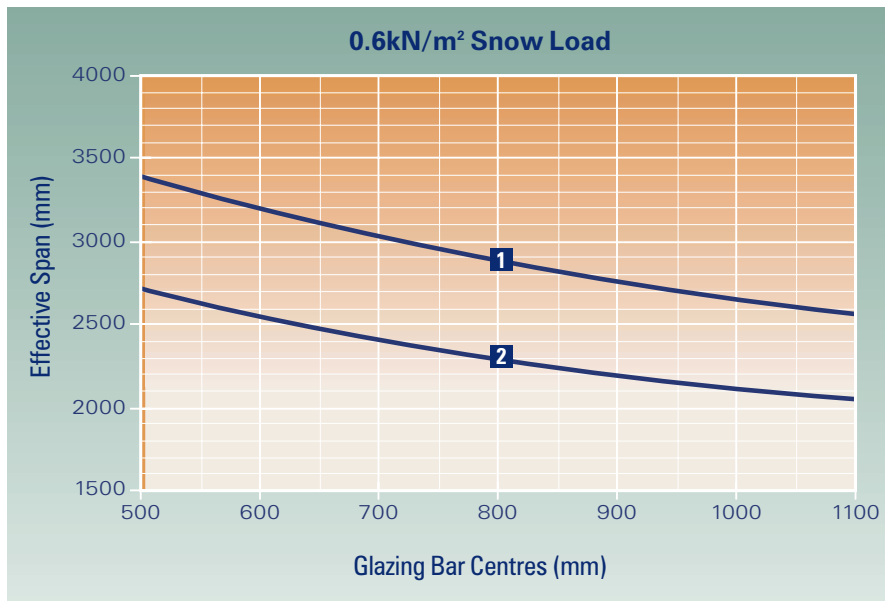

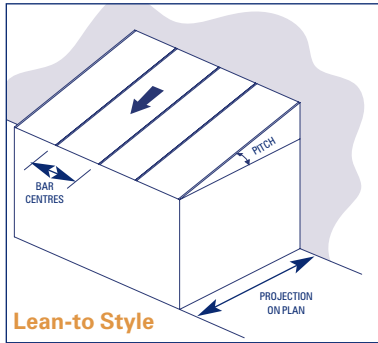

POLYCARBONATE

Example Calculation

Projection on plan multiplied by slope factor table below equals effective span.

Example: 3000mm projection multiplied by 1.025 (15 degrees) equals 3075mm effective span.

Slope Calculation Factor						
Slope Angle (degrees)	5	10	15	20	25	30
Span Multiplication Factor	1.003	1.011	1.025	1.044	1.070	1.104

- 1** : 25mm Heavy Duty Bar With Bolster/
35mm Aspire With Bolster
- 2** : 16mm Heavy Duty Bar With Bolster
- 3** : 25mm Heavy Duty Bar/35mm Aspire
- 4** : 16mm Heavy Duty Bar
- 5** : 25mm Standard Bar
- 6** : 16mm Standard Bar

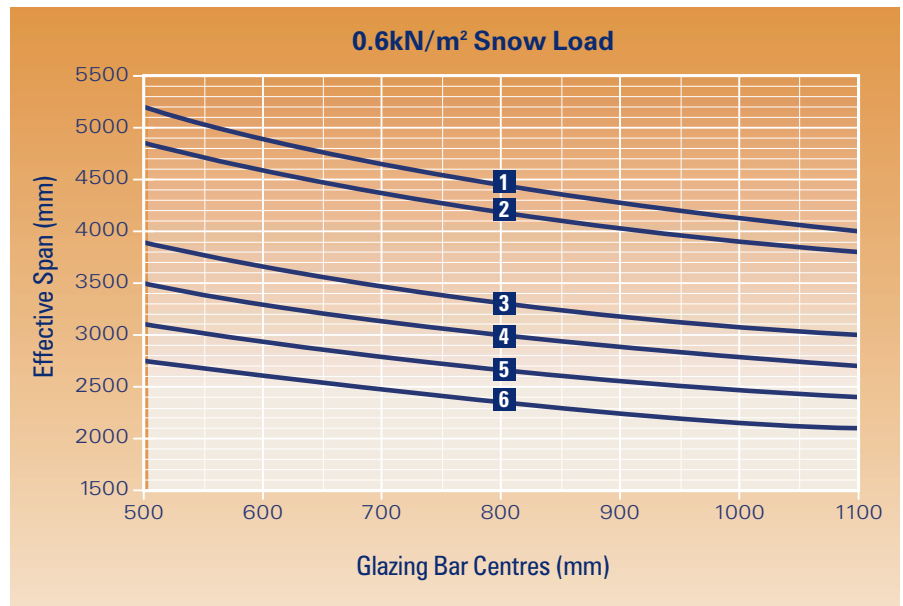

- 1** : 25mm Heavy Duty Bar With Bolster/
35mm Aspire With Bolster
- 2** : 16mm Heavy Duty Bar With Bolster
- 3** : 25mm Heavy Duty Bar/35mm Aspire
- 4** : 16mm Heavy Duty Bar
- 5** : 25mm Standard Bar
- 6** : 16mm Standard Bar

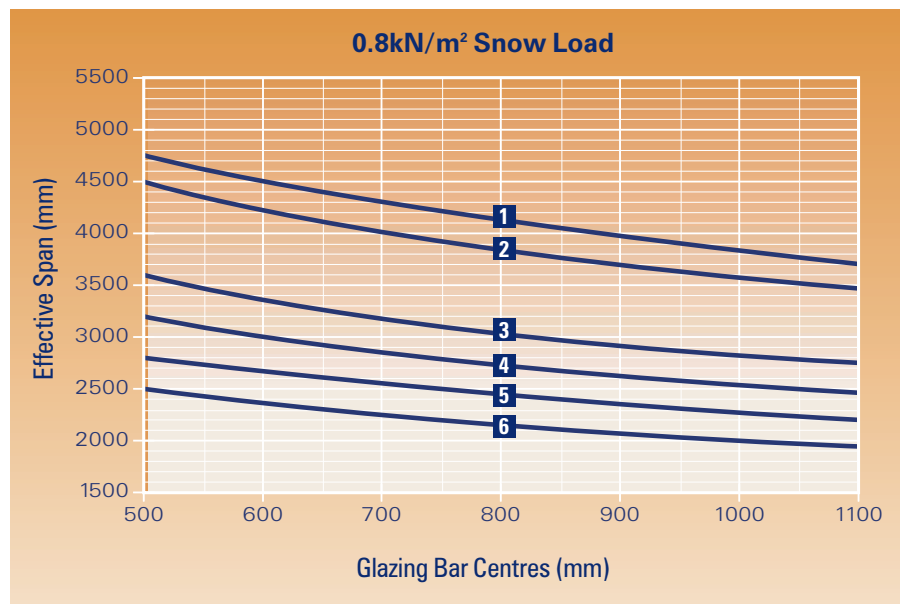

LEAN-TO TRANSOM SPAN CHART

STRUCTURAL GUIDE

DOUBLE GLAZED UNITS (4:16:4mm)

Example Calculation

Projection on plan multiplied by slope factor table below equals effective span.

Example: 3000mm projection multiplied by 1.025 (15 degrees) equals 3075mm effective span.

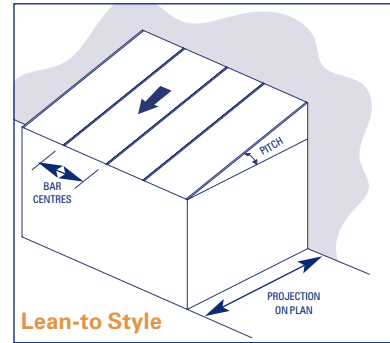

Slope Calculation Factor

Slope Angle (degrees)	5	10	15	20	25	30
Span Multiplication Factor	1.003	1.011	1.025	1.044	1.070	1.104

0.6kN/m² Snow Load

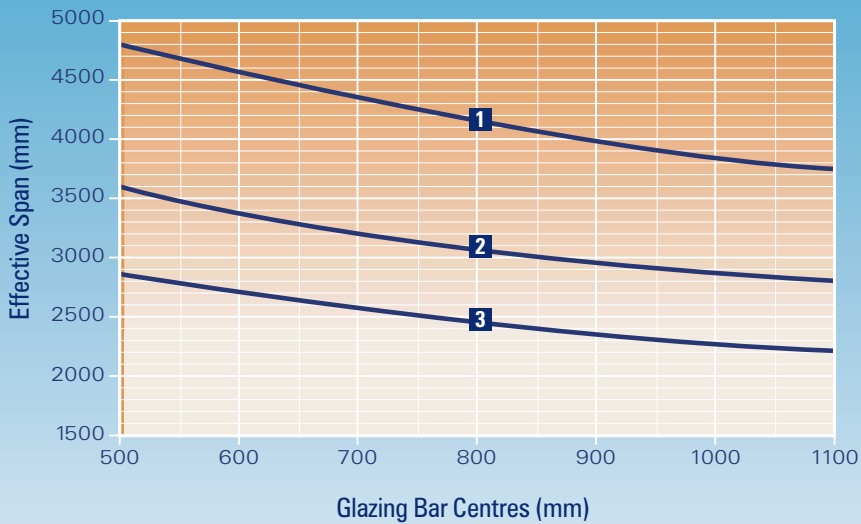

- 1** : 25mm Heavy Duty Bar With Bolster
- 2** : 25mm Heavy Duty Bar
- 3** : 25mm Standard Bar

0.8kN/m² Snow Load

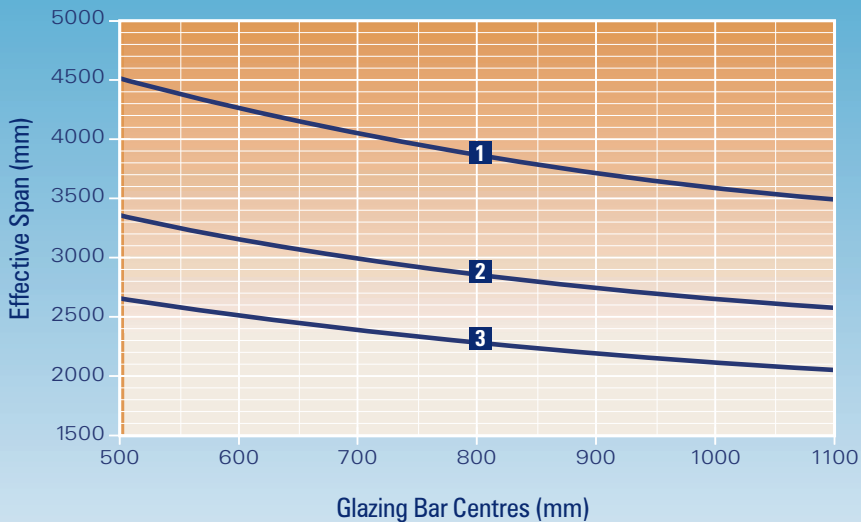

- 1** : 25mm Heavy Duty Bar With Bolster
- 2** : 25mm Heavy Duty Bar
- 3** : 25mm Standard Bar

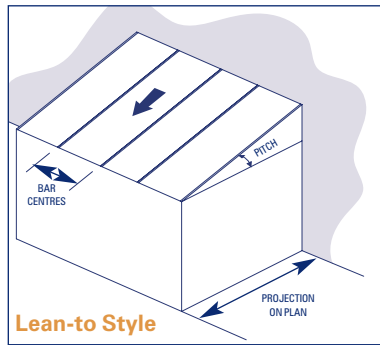

DOUBLE GLAZED UNITS (4:14:6.4mm)

Example Calculation

Projection on plan multiplied by slope factor table below equals effective span.

Example: 3000mm projection multiplied by 1.025 (15 degrees) equals 3075mm effective span.

Slope Calculation Factor						
Slope Angle (degrees)	5	10	15	20	25	30
Span Multiplication Factor	1.003	1.011	1.025	1.044	1.070	1.104

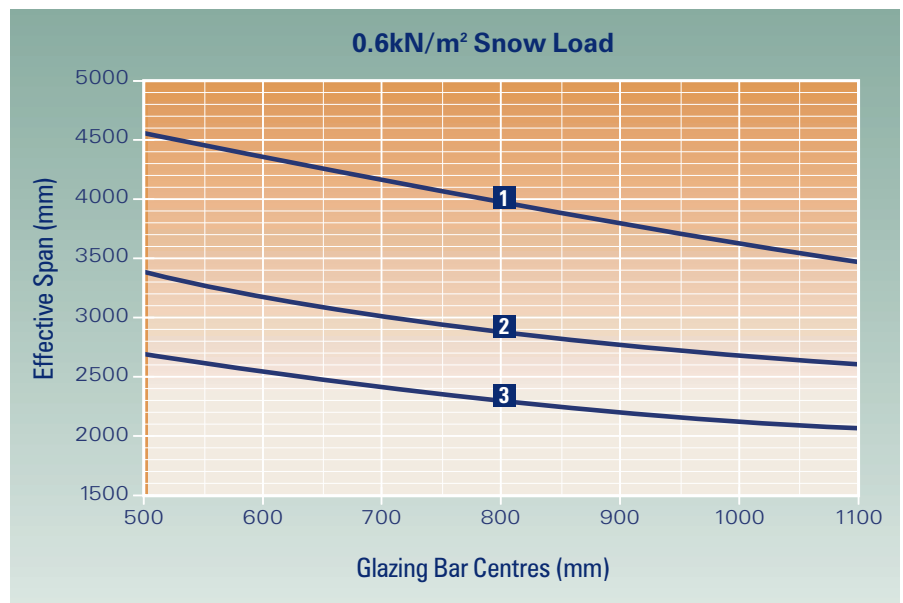

- 1** : 25mm Heavy Duty Bar With Bolster
- 2** : 25mm Heavy Duty Bar
- 3** : 25mm Standard Bar

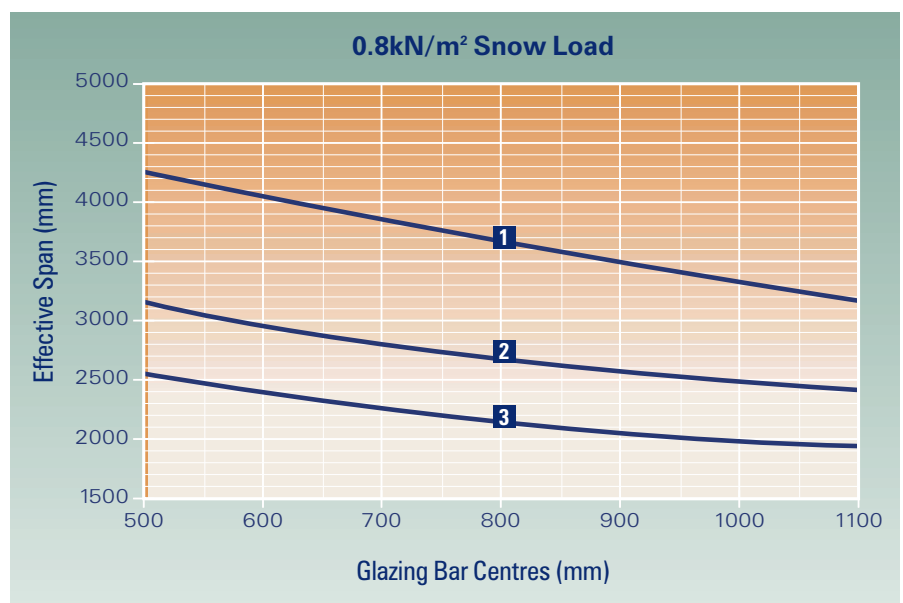

- 1** : 25mm Heavy Duty Bar With Bolster
- 2** : 25mm Heavy Duty Bar
- 3** : 25mm Standard Bar

TRANSOM SPAN CHART
STRUCTURAL GUIDE

35mm LOW PITCH SYSTEM

POLYCARBONATE

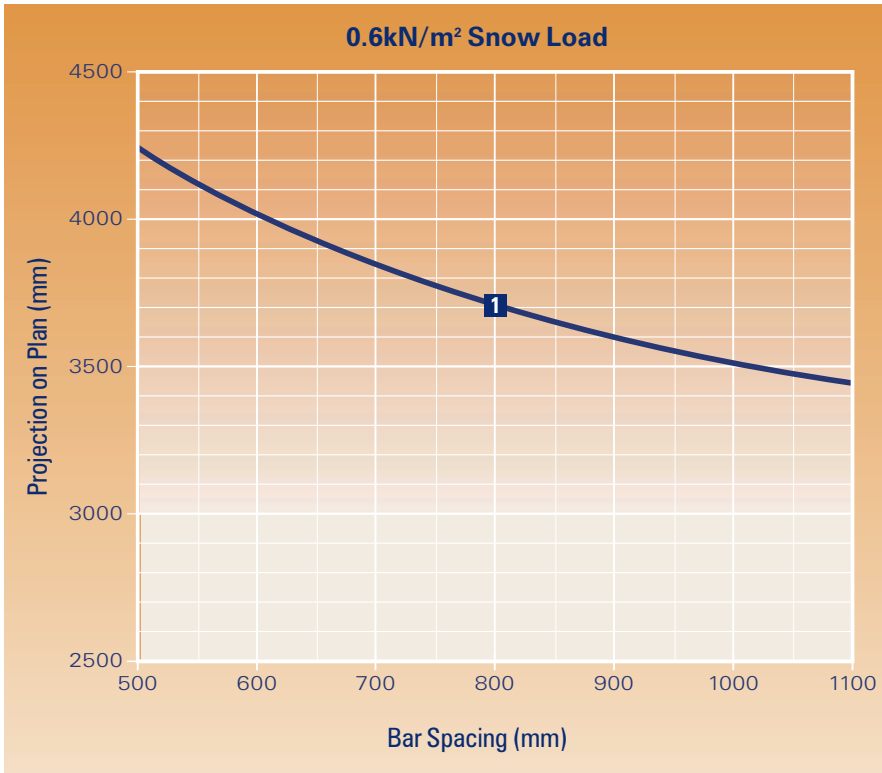
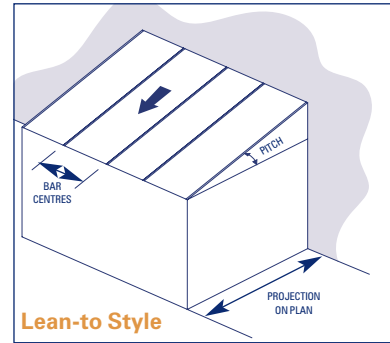

1 : 35mm Heavy Duty Bar

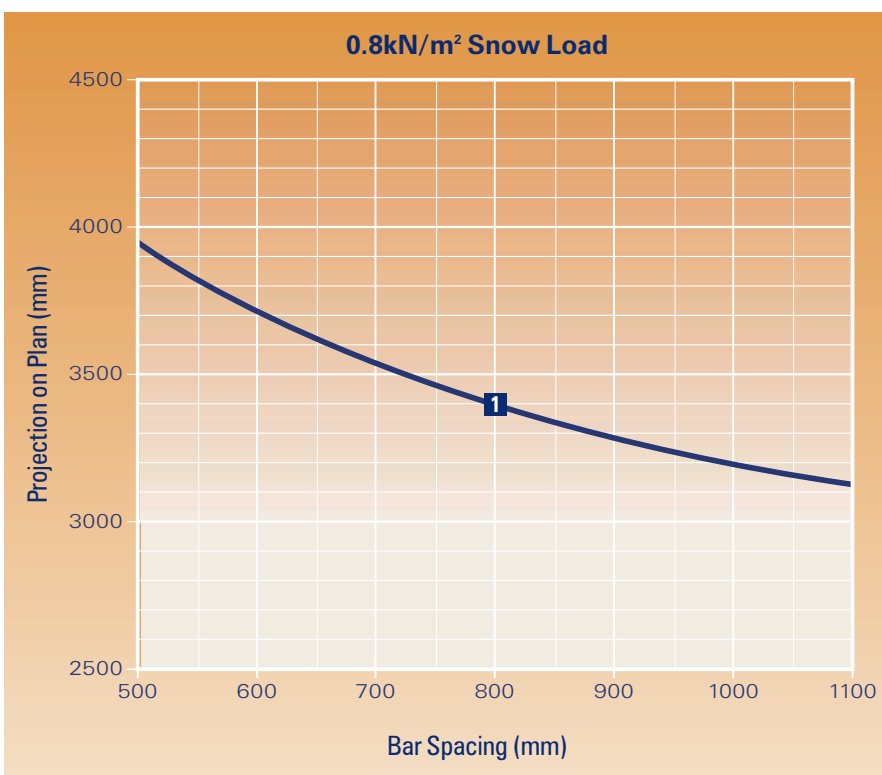

1 : 35mm Heavy Duty Bar

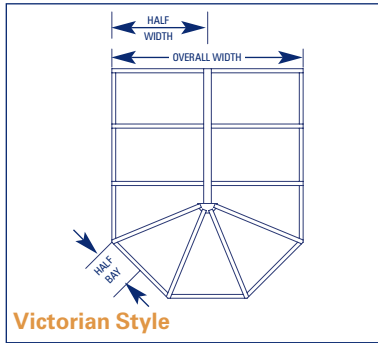

POLYCARBONATE

Victorian Style

Half width multiplied by slope factor table below equals effective span.

Lean to with Victorian Hips

Projection on plan multiplied by slope factor table below equals effective span.

Transom glazing bars can either be jack rafters or splayed when used with Victorian style roofs.

Slope Calculation Factor						
Slope Angle (degrees)	5	10	15	20	25	30
Span Multiplication Factor	1.003	1.011	1.025	1.044	1.070	1.104

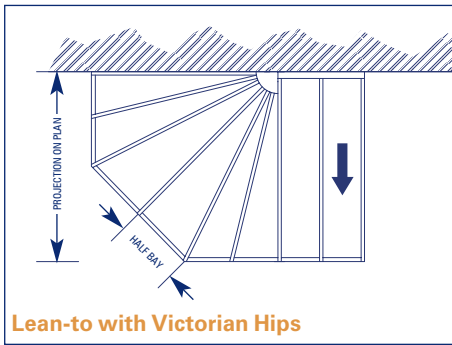

- 1** : 25mm Heavy Duty Bar With Bolster/
35mm Aspire With Bolster
- 2** : 16mm Heavy Duty Bar With Bolster
- 3** : 25mm Heavy Duty Bar/35mm Aspire
- 4** : 16mm Heavy Duty Bar
- 5** : 25mm Standard Bar
- 6** : 16mm Standard Bar

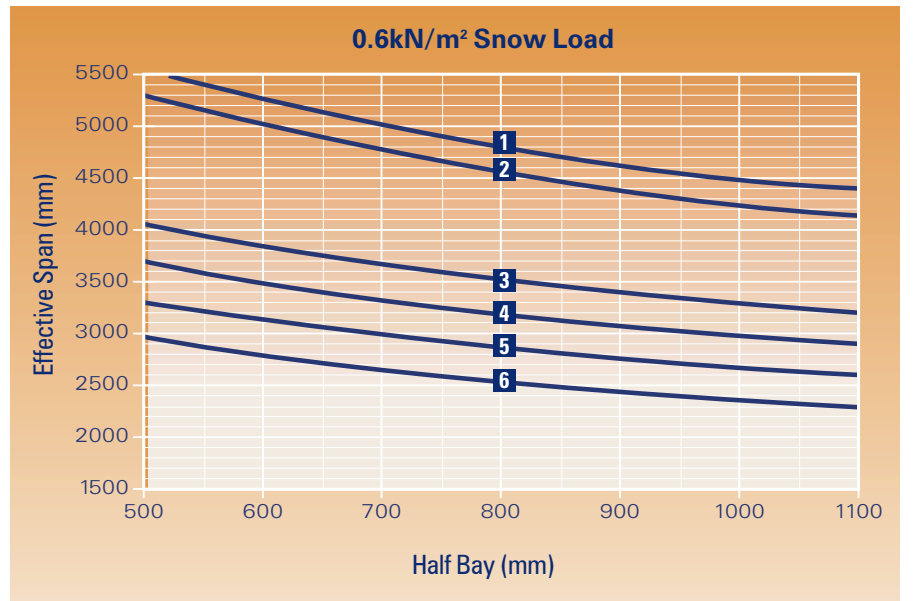

Please note that overall sizes of the roof design must not exceed those stated in section 1.

- 1** : 25mm Heavy Duty Bar With Bolster/
35mm Aspire With Bolster
- 2** : 16mm Heavy Duty Bar With Bolster
- 3** : 25mm Heavy Duty Bar/35mm Aspire
- 4** : 16mm Heavy Duty Bar
- 5** : 25mm Standard Bar
- 6** : 16mm Standard Bar

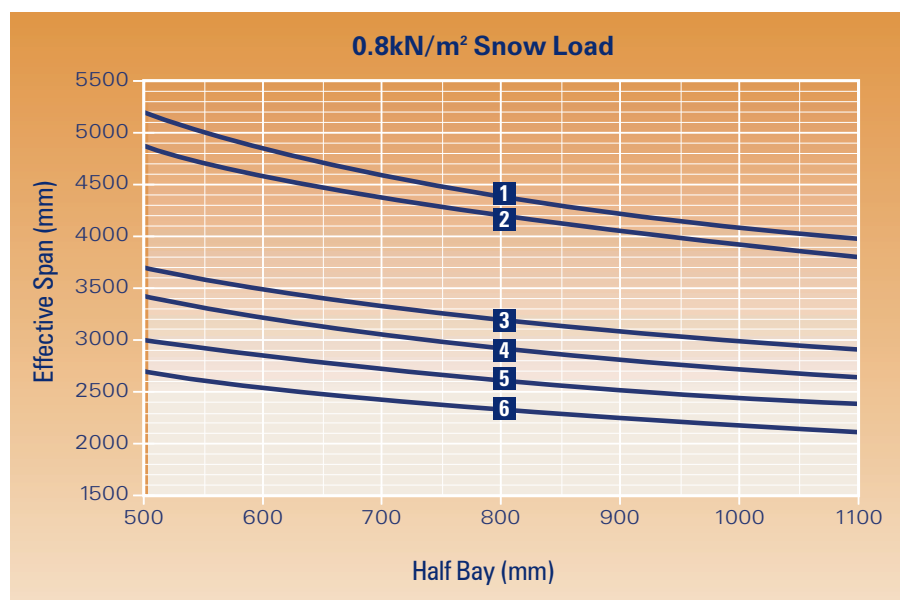

VICTORIAN HIP SPAN CHART

STRUCTURAL GUIDE

DOUBLE GLAZED UNITS (4:16:4mm)

Victorian Style

Half width multiplied by slope factor table below equals effective span.

Lean to with Victorian Hips

Projection on plan multiplied by slope factor table below equals effective span.

Transom glazing bars can either be jack rafters or splayed when used with Victorian style roofs.

Slope Calculation Factor

Slope Angle (degrees)	5	10	15	20	25	30
Span Multiplication Factor	1.003	1.011	1.025	1.044	1.070	1.104

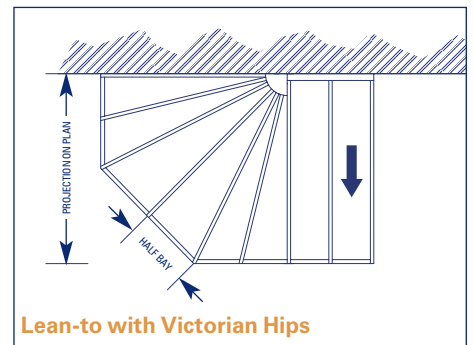
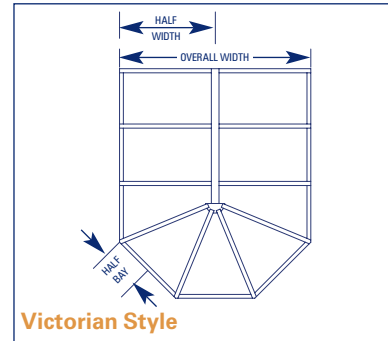

- 1** : 25mm Heavy Duty Bar With Bolster
- 2** : 25mm Heavy Duty Bar
- 3** : 25mm Standard Bar

Please note that overall sizes of the roof design must not exceed those stated in section 1.

- 1** : 25mm Heavy Duty Bar with Bolster
- 2** : 25mm Heavy Duty Bar
- 3** : 25mm Standard Bar

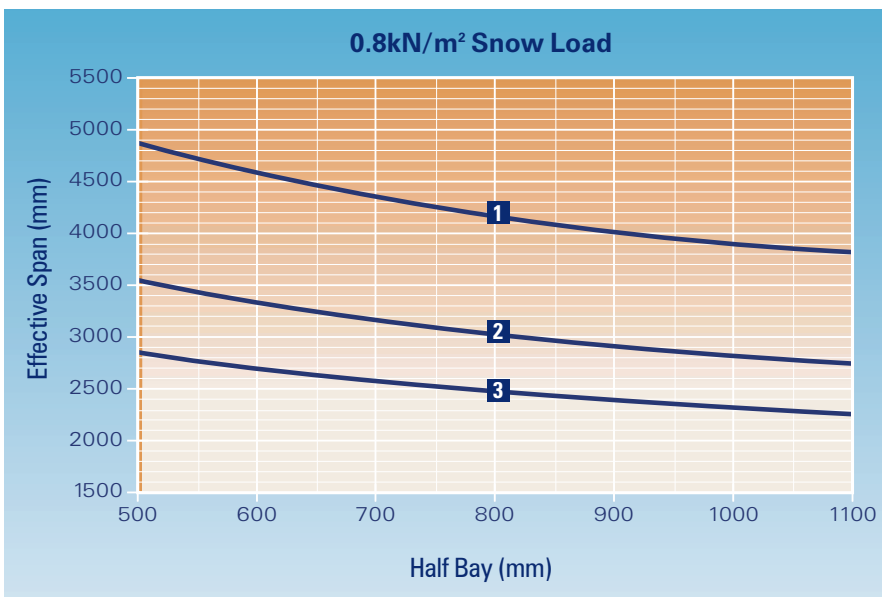
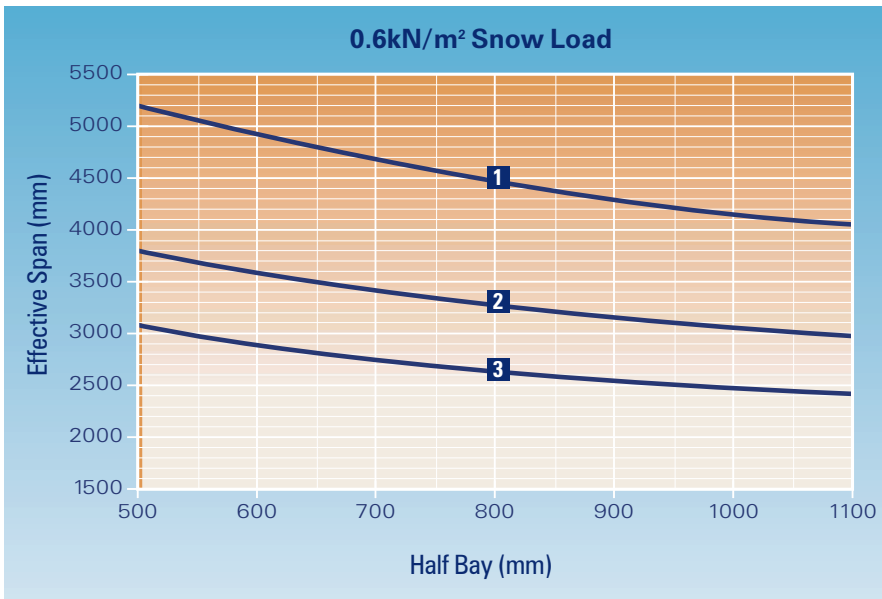

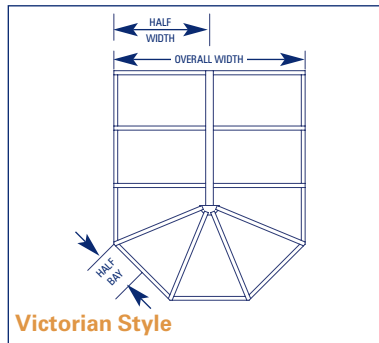

DOUBLE GLAZED UNITS (4:14:6.4mm)

Victorian Style

Half width multiplied by slope factor table below equals effective span.

Lean to with Victorian Hips

Projection on plan multiplied by slope factor table below equals effective span.

Transom glazing bars can either be jack rafters or splayed when used with Victorian style roofs.

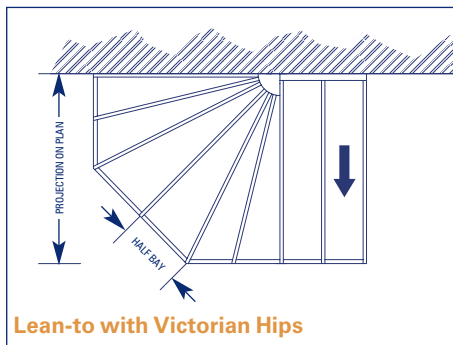

Slope Calculation Factor						
Slope Angle (degrees)	5	10	15	20	25	30
Span Multiplication Factor	1.003	1.011	1.025	1.044	1.070	1.104

- 1** : 25mm Heavy Duty Bar With Bolster
- 2** : 25mm Heavy Duty Bar
- 3** : 25mm Standard Bar

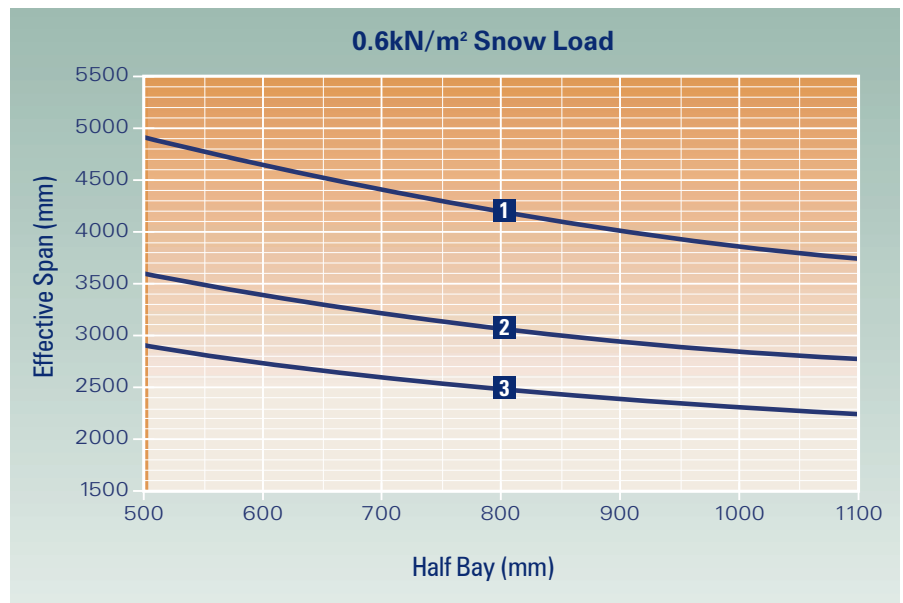

Please note that overall sizes of the roof design must not exceed those stated in section 1.

- 1** : 25mm Heavy Duty Bar With Bolster
- 2** : 25mm Heavy Duty Bar
- 3** : 25mm Standard Bar

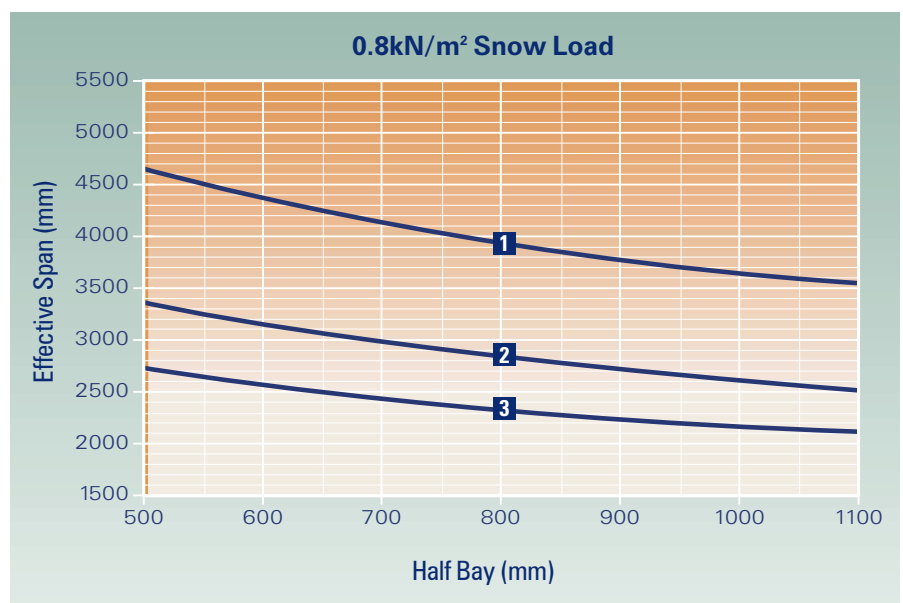

GEORGIAN HIP SPAN CHART

STRUCTURAL GUIDE

POLYCARBONATE

Projection and half width on plan should be taken to calculate the correct Georgian hip bar to be used on the roof. The transom glazing bars can be either jack rafters or splayed.

Please note that overall sizes of the roof design must not exceed those stated in section 1.

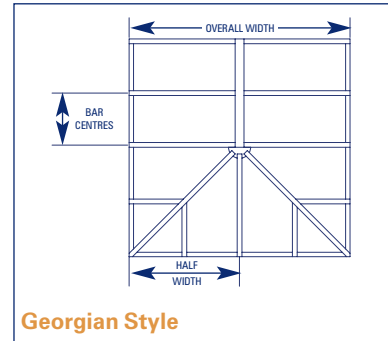

Georgian Style

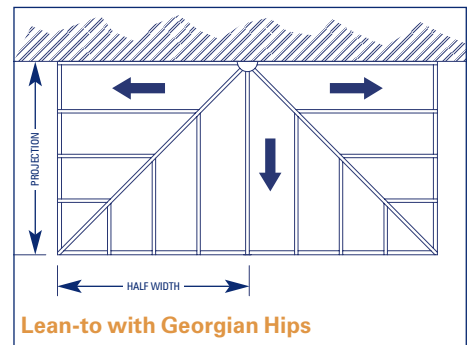

Lean-to with Georgian Hips

- 1** : 25mm Heavy Duty Bar With Bolster/
35mm Aspire With Bolster
- 2** : 16mm Heavy Duty Bar With Bolster
- 3** : 25mm Heavy Duty Bar/35mm Aspire
- 4** : 16mm Heavy Duty Bar
- 5** : 25mm Standard Bar
- 6** : 16mm Standard Bar

- 1** : 25mm Heavy Duty Bar With Bolster/
35mm Aspire With Bolster
- 2** : 16mm Heavy Duty Bar With Bolster
- 3** : 25mm Heavy Duty Bar/35mm Aspire
- 4** : 16mm Heavy Duty Bar
- 5** : 25mm Standard Bar
- 6** : 16mm Standard Bar

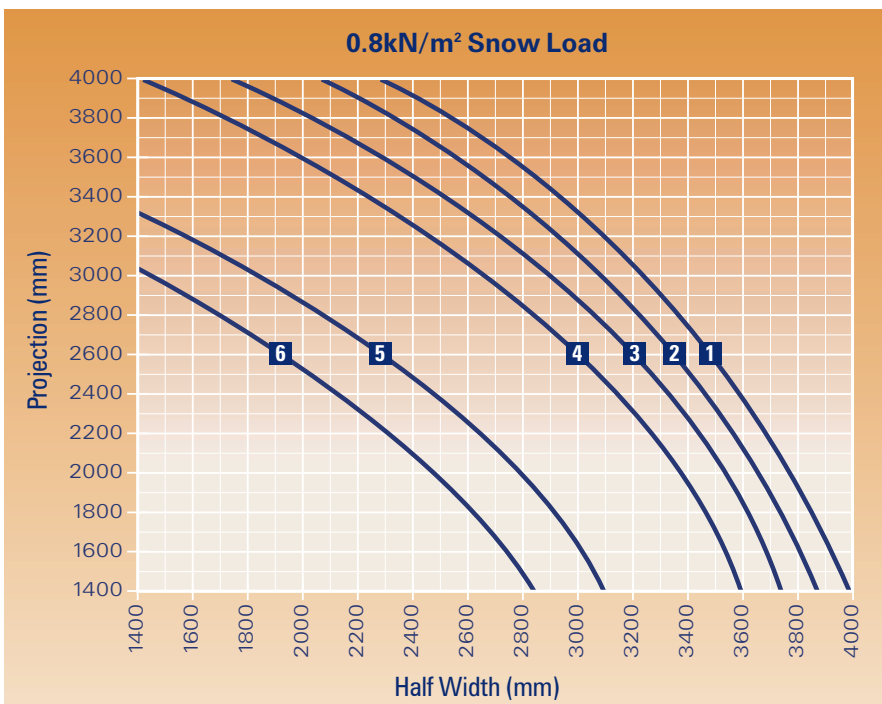
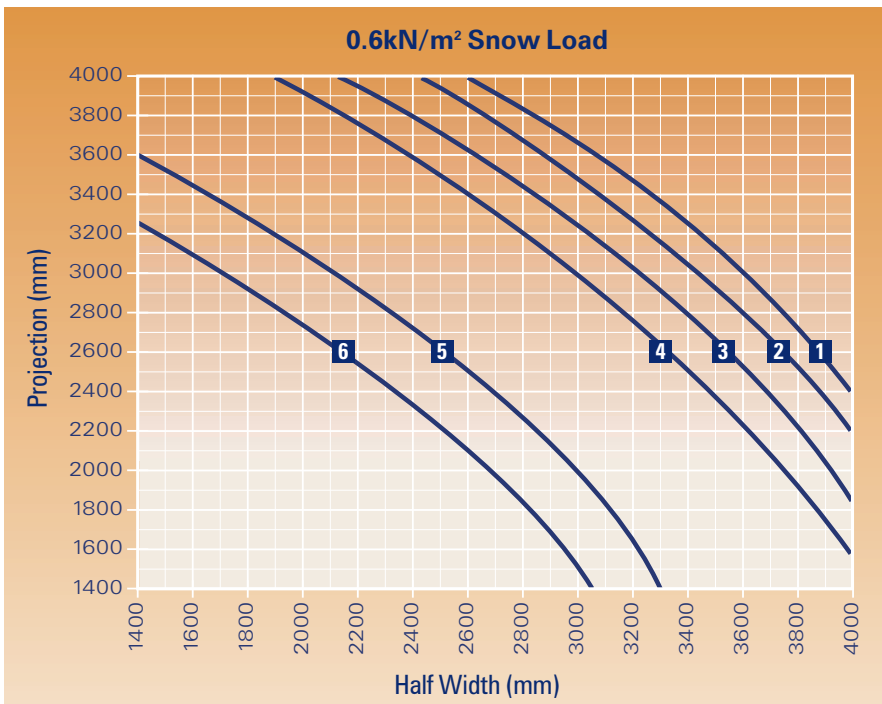

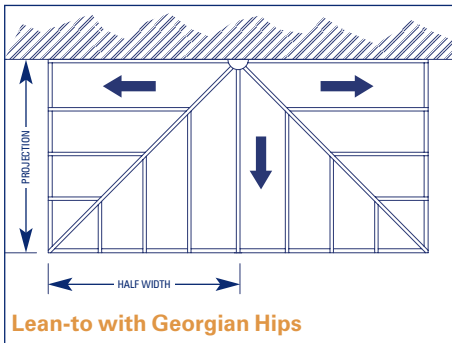
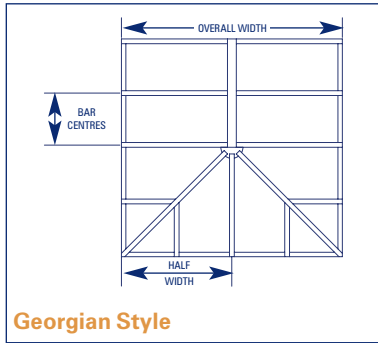

- 1** : 25mm Heavy Duty Bar With Bolster
- 2** : 25mm Heavy Duty Bar
- 3** : 25mm Standard Bar

- 1** : 25mm Heavy Duty Bar with Bolster
- 2** : 25mm Heavy Duty Bar
- 3** : 25mm Standard Bar

DOUBLE GLAZED UNITS (4:16:4mm)

Projection and half width on plan should be taken to calculate the correct Georgian hip bar to be used on the roof. The transom glazing bars can be either jack rafters or splayed.

Please note that overall sizes of the roof design must not exceed those stated in section 1.

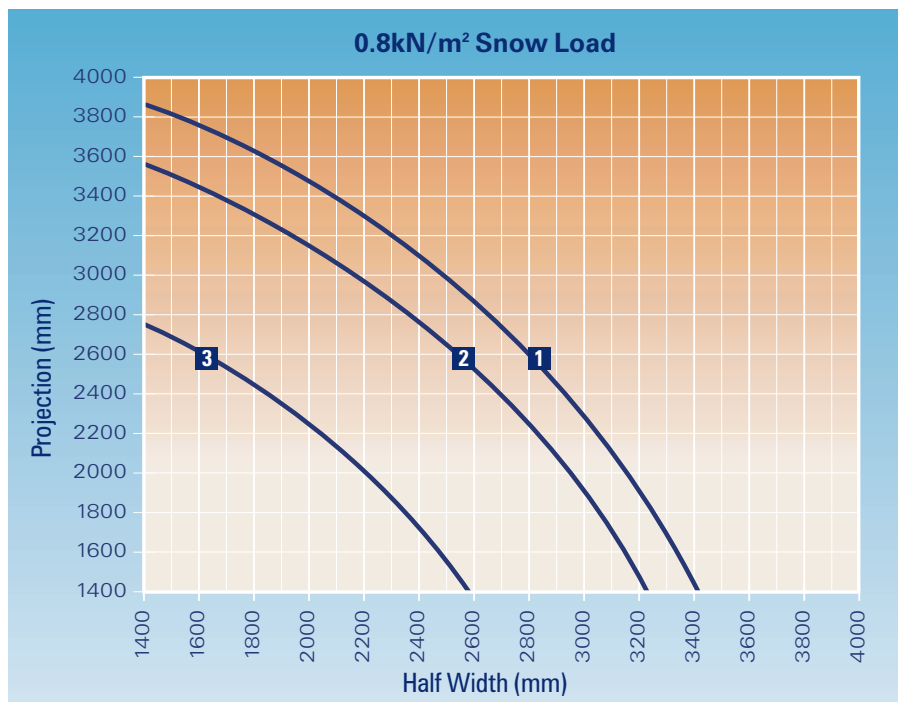
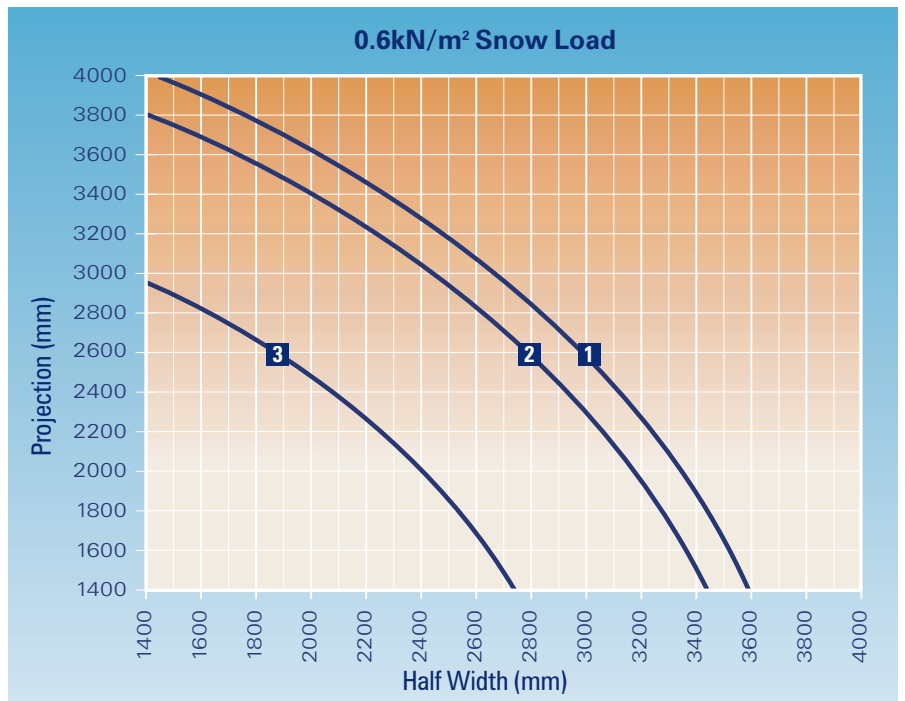

GEORGIAN HIP SPAN CHART

STRUCTURAL GUIDE

DOUBLE GLAZED UNITS (4:14:6.4mm)

Projection and half width on plan should be taken to calculate the correct Georgian hip bar to be used on the roof. The transom glazing bars can be either jack rafters or splayed.

Please note that overall sizes of the roof design must not exceed those stated in section 1.

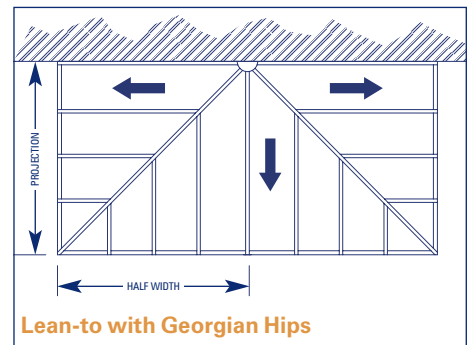
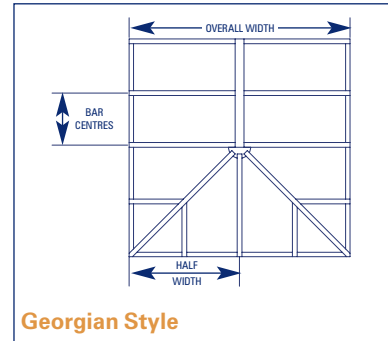

- 1** : 25mm Heavy Duty Bar With Bolster
- 2** : 25mm Heavy Duty Bar
- 3** : 25mm Standard Bar

- 1** : 25mm Heavy Duty Bar with Bolster
- 2** : 25mm Heavy Duty Bar
- 3** : 25mm Standard Bar

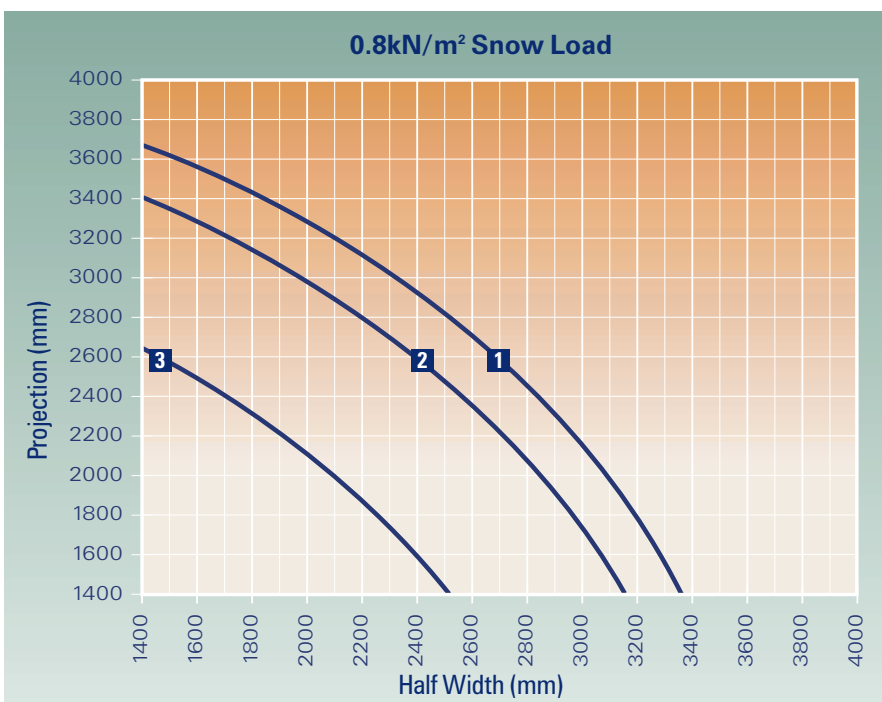
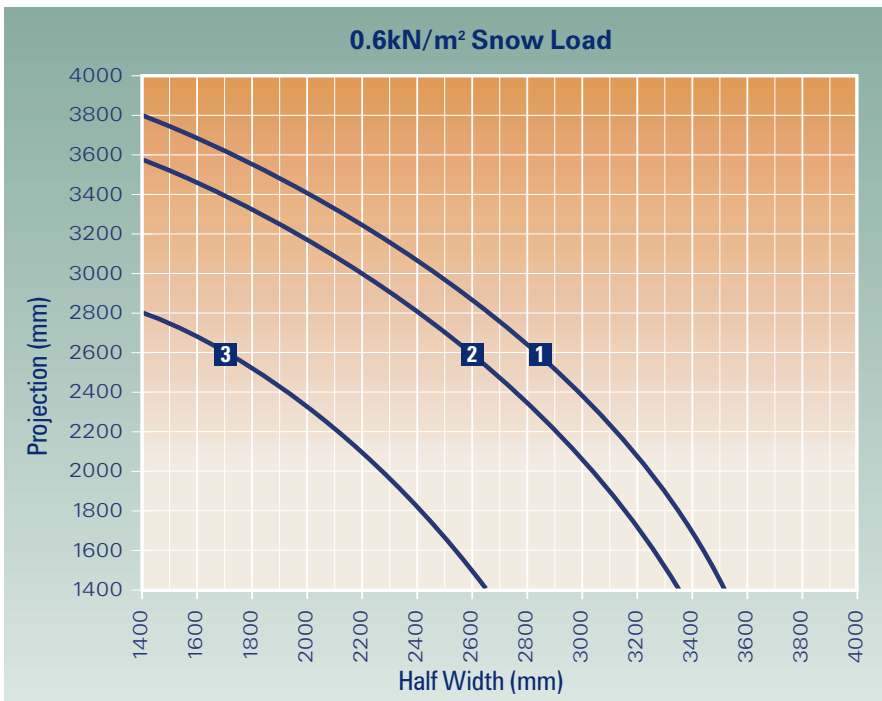

Tie Bar Rules

- When a tie bar is required it must be installed in line with the pair of glazing bars closest to the end of the ridge. (Max distance from end of ridge 750mm.)
- When multiple tie bars are required, the first one is to be positioned as described above with the remaining bars positioned at equal intervals between the first tie bar and the wall.
- For advice on sizes outside the following charts contact the K2 Technical Department.
- Special rules apply to free-standing and double ended conservatories. Contact the K2 Technical Department for advice.
- On the following tables it is assumed that the conservatories are attached to the house wall at the rear and that the roof pitches are equal on all sides.
- The following tables are relevant to areas with a maximum snow load of 0.8 kN/m².

How the Tie Bar Works

Tie bars are a mechanism used to laterally restrain movement in opposing eaves beams. By securing a tie bar between two eaves beams, the spread effect created by loads placed on the roof (wind, snow, glass etc.) is prevented.

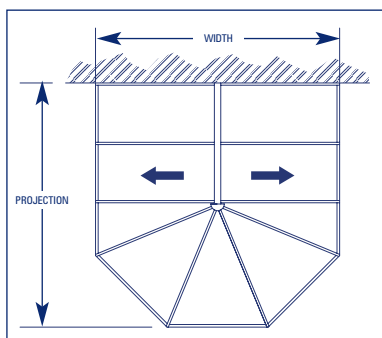
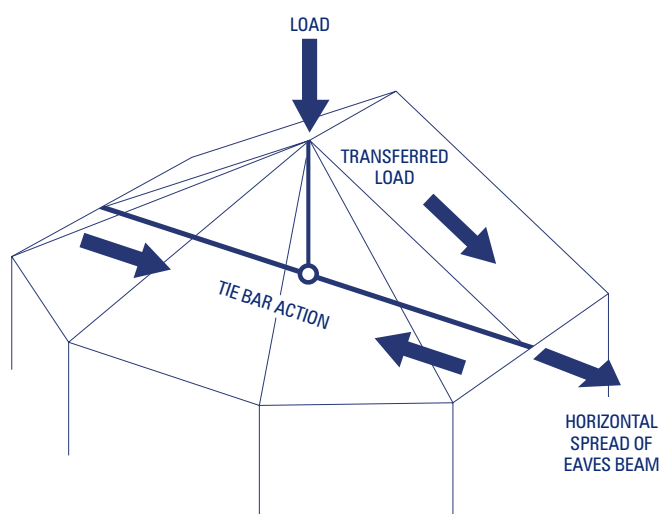

Victorian

These tie bar tables can be used for either 3 or 5 bay victorian roofs.

The tables have been based on the roof having the same pitch on all sides.

		Glass							
		PROJECTION							
		3000	3500	4000	4500	5000	5500	6000	6500
WIDTH	3000	0	1	2	2	2	2	2	2
	3500	0	1	2	2	2	2	2	2
	4000	0	1	2	2	2	2	2	2
	4500	0	1	1	2	2	2	2	2
	5000	0	1	1	2	2	2	2	2
	5500	0	1	1	1	2	2	2	2
	5750	0	1	1	1	2	2	2	2

		Polycarbonate							
		PROJECTION							
		3000	3500	4000	4500	5000	5500	6000	6500
WIDTH	3000	0	0	1	2	2	2	2	2
	3500	0	0	1	2	2	2	2	2
	4000	0	0	1	2	2	2	2	2
	4500	0	0	1	1	2	2	2	2
	5000	0	0	1	1	2	2	2	2
	5500	0	0	1	1	1	2	2	2
	6000	0	0	1	1	1	2	2	2
	6500	0	0	1	1	1	2	2	2

TIE BAR RULES

STRUCTURAL GUIDE

Georgian

These tie bar tables are for georgian roofs only.

The tables have been based on roof having the same pitch on all sides.

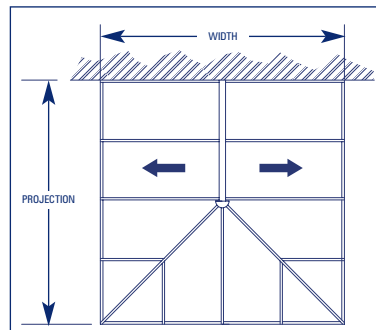

		Glass							
		PROJECTION							
		3000	3500	4000	4500	5000	5500	6000	6500
WIDTH	3000	0	1	2	2	2	2	2	2
	3500	0	1	2	2	2	2	2	2
	4000	0	1	2	2	2	2	2	2
	4500	0	1	1	2	2	2	2	2
	5000	0	1	1	2	2	2	2	2
	5250	0	1	1	1	2	2	2	2

		Polycarbonate							
		PROJECTION							
		3000	3500	4000	4500	5000	5500	6000	6500
WIDTH	3000	0	0	1	2	2	2	2	2
	3500	0	0	1	2	2	2	2	2
	4000	0	0	1	2	2	2	2	2
	4500	0	0	1	1	2	2	2	2
	5000	0	0	1	1	2	2	2	2
	5500	0	0	1	1	1	2	2	2
	6000	0	0	1	1	1	2	2	2

Gable

The following have been based on the roofs having equal pitch on both sides and with one gable end attached to the building.

When gable roofs are built with a continuous eaves beam, tie bars must be equally spaced along the ridge.

In cases where the eaves beam is non-continuous, the first tie bar must be positioned under the first set of glazing bars behind the gable frame.

In all cases the maximum distance between sets of bars must not exceed 2400mm.

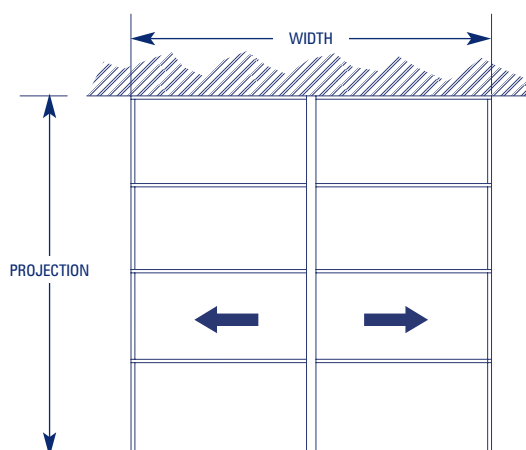

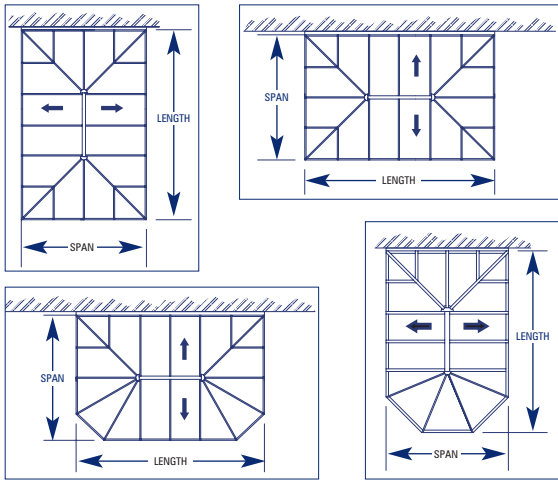

		Glass							
		3	3.5	4	LENGTH (m)				
					4.5	5	5.5	6	6.5
SPAN (m)	3	1	1	1	2	2	2	3	3
	3.5		1	1	2	2	2	2	3
	4			1	2	2	2	2	3
	4.5				1	2	2	2	2
	5					1	2	2	2
	5.25							2	2

Double Ended Ridges/Hipped Back Roofs

When one set of tie bars is required, it should be positioned centrally along the ridge.

If two or more sets are required, two should be positioned as close to the finial points as possible .

For roofs outside of these parameters please contact the K2 Technical Department for advice.

5 Way Tie Bars

		Polycarbonate							
		3	3.5	4	LENGTH (m)				
					4.5	5	5.5	6	6.5
SPAN (m)	3	0	0	0	1	1	2	3	3
	3.5		0	1	1	2	2	2	3
	4			1	2	2	2	2	2
	4.5				1	2	2	2	2
	5					1	2	2	2
	5.5						1	2	2
	6							1	2

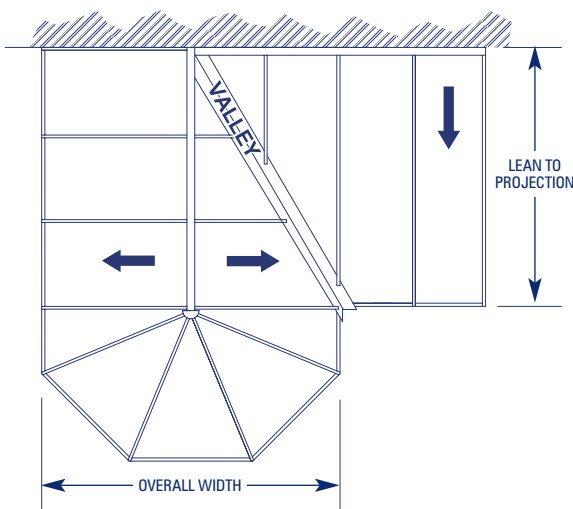

P-Shaped Conservatories

1. Victorian and Georgian roofs greater than 3000mm in width require a tie bar.
2. If possible the tie bar should be positioned in line with the front edge of the lean to section. If this is not possible the tie bar can be positioned up to a maximum of $\frac{1}{4}$ way up the valley.
3. If possible the finial point of the main ridge should be inline with the front edge of the lean to section or beyond it.
4. Under no circumstances should bolster bars be fitted on roof designs incorporating valleys.
5. Tie bars must be positioned beneath glazing bars.

www.k2conservatories.com



K2 CONSERVATORY ROOF SYSTEMS (UK)

Burnden Works, Burnden Road, Bolton, Lancashire BL3 2RB
Tel: +44 (0)1204 554 554 Fax: +44 (0)1204 554 577
email: enquiry@k2conservatories.com www.k2conservatories.com

K2 (USA) CONSERVATORY SYSTEMS, INC.

Airport Technical Center, 136 West 64th Street, Holland, MI 49423
Tel: +1 616 796 9940 Fax: +1 616 394 3004
email: inquiry@k2conservatories.us www.k2conservatories.us



FM54162

